

# K23-N

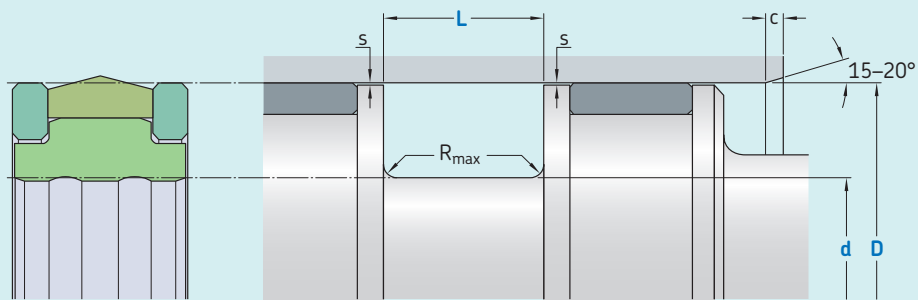

Ordering dimensions in **blue**

Surface roughness	$R_{tmax}$	$R_a$
	μm	

**Sliding surface**     $\leq 2,5$      $0,05-0,2$

**Bottom of groove**     $\leq 6,3$      $\leq 1,6$

**Groove face**     $\leq 15$      $\leq 3$

Bearing area: 50-95% and a cutting depth of 0,5  $R_z$  based on  $C_{ref} = 0\%$

### Standard dimensions

D	d	L	$R_{max}$	c	$s^*$
H9	h9	+ 0,2			400 bar
over	incl.				
mm					
<b>20</b>	<b>50</b>	D - 10	12,5	0,4	0,35
<b>50</b>	<b>80</b>	D - 15	20,0	0,4	0,52
<b>80</b>	<b>150</b>	D - 20	25,0	0,4	0,65
<b>150</b>	<b>400</b>	D - 25	32,0	0,4	0,78
<b>400</b>	<b>600</b>	D - 30	36,0	0,4	1,00

\* Extrusion gap values shown above are valid for a temperature of 70 °C, higher temperatures require lower values.

### Ordering example

Profile  
 D x d x L [mm]  
 Sealing material / Energizer / Back-up ring

Piston seal K23-N  
**100 x 80 x 25**  
 ECOPUR / SKF Ecorubber-1 / SKF Ecotal

## Operating parameters

Material Seal	Energizer	Back-up ring <sup>3)</sup>	Temperature		Speed <sup>1)</sup>	Pressure <sup>2)</sup>
			from	to	max	max
			°C		m/s	bar (MPa)
■ ECOPUR	■ SKF Ecorubber-1	■ SKF Ecotal	-30	+100	0,5	400 (40)
■ ECOPUR	■ SKF Ecorubber-1	■ SKF Ecomid	-30	+100	0,5	400 (40)
■ H-ECOPUR	■ SKF Ecorubber-1	■ SKF Ecotal	-30	+100	0,5	400 (40)
■ H-ECOPUR	■ SKF Ecorubber-1	■ SKF Ecomid	-30	+100	0,5	400 (40)
■ S-ECOPUR	■ SKF Ecorubber-1	■ SKF Ecotal	-30	+100	0,5	400 (40)
■ S-ECOPUR	■ SKF Ecorubber-1	■ SKF Ecomid	-30	+100	0,5	400 (40)
■ T-ECOPUR	■ SKF Ecosil	■ SKF Ecotal	-60	+100	0,5	400 (40)
■ T-ECOPUR	■ SKF Ecosil	■ SKF Ecomid	-60	+100	0,5	400 (40)

IMPORTANT NOTE: The stated operating conditions represent general indications. It is recommended not to use all maximum values simultaneously.

1) Surface speed limit values are valid only in the presence of a lubrication film.

2) Pressure ratings depend on the size of the extrusion gap.

3) Size limitation D: Up to 260 mm SKF Ecotal, from 260 – 400 mm SKF Ecotal or SKF Ecomid and above 400 mm SKF Ecomid.